

## Product Data

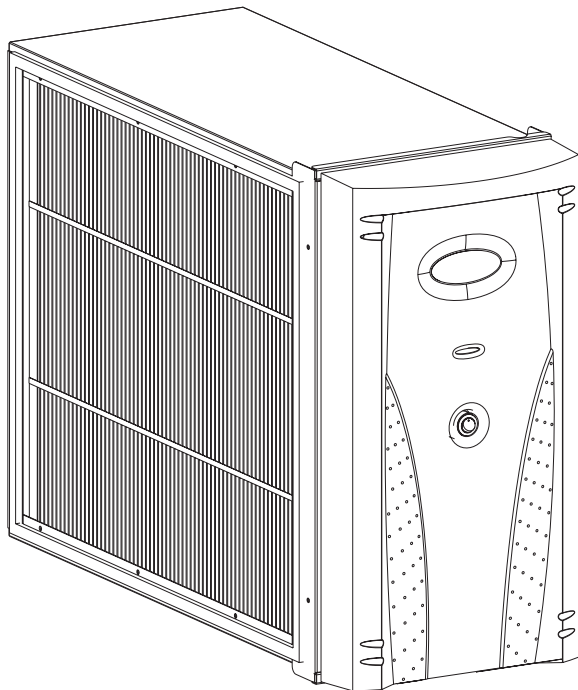

A05265

**Fig. 1 – GAPAA Unit**

The Infinity™ Air Purifier is designed for use in the return air duct of a forced air heating, cooling, and ventilation system. Models GAPAAAXCC1625 and GAPAAAXCC2025 are specifically designed for use in systems with a forced air gas furnace and are intended to be powered by 115v/60 Hz.

The Infinity™ Air Purifier both captures and kills airborne viruses, bacteria, mold spores, and allergens. It combines superior filtration efficiency, equivalent to MERV 15, with pathogen-killing technology to deliver maximum air purification.

The Infinity Air Purifier™ offers worry-free operation, requiring no cleaning. Maintenance is limited to the periodic replacement of the special media cartridge.

### FEATURES/BENEFITS

**Performance**—Ultra-high efficiency equivalent to MERV 15. Captures and kills airborne viruses, bacteria, and mold spores.

**Simple**—Virtually no cleaning required. Simply change purifier cartridge periodically.

**Easy to Install**—Two distinct cabinet sizes help to ensure a perfect fit to the bottom and side of most Carrier furnaces.

**Application Possibilities**—Unit can be installed in a horizontal or vertical position, which makes it equally adaptable to horizontal, downflow, or standard upflow applications.

**Solid-State Power Supply**—Power supply is a highly reliable state-of-the-art, solid-state, high-voltage device.

**Durable Cabinet**—Heavy-gage steel cabinet supports up to 400 lb when installed beneath an upflow furnace.

**Agency Listed**—Model GAPA Air Purifier is cCSAus listed.

**Financing**—Eligible for consumer financing program.

**Limited Warranty**—Five-year warranty on the unit with a \$25 labor allowance for service calls within the first 120 days after installation. 5-year warranty on power supply with \$50 labor allowance, within the first 120 days.

**INFINITY™** SERIES



# SPECIFICATIONS AND DIMENSIONS

Specifications	GAPAAAXCC1625	GAPAAAXCC2025
Color	Taupe Metallic	Taupe Metallic
Cabinet Material	20 Ga. Powder Coated Steel	20 Ga. Powder Coated Steel
Cabinet Construction	Epoxy powdered steel; supports 400 lb	Epoxy powdered steel; supports 400 lb
Electrical	115v/60 Hz (from furnace EAC terminals)	115v/60 Hz (from furnace EAC terminals)
Typical Input Power (Watts)	18	18
Input Amps	.25	.25
Maximum Airflow (CFM)	1600	2000
Efficiency	Equivalent to MERV 15	Equivalent to MERV 15
Replacement Cartridge	GAPCCCAR1625	GAPCCCAR2025
Dimensions	GAPAAAXCC1625	GAPAAAXCC2025
A	18-3/8	21-7/8
B	15-1/8	18-5/8
C	11-1/8	11-1/8
D	17-1/2	21
E	22-1/8	22-1/8
F	25-1/4	25-1/4

GAPAA

## PRESSURE DROP AT VARIOUS INTERVALS (CLEAN)

Size	Typical 16 X 25	Typical 20 X 25
Airflow (CFM)	Resistance (inches of water) (Clean filter)	
400	0.035	0.03
800	0.09	0.07
1200	0.16	0.115
1600	0.25	0.175
2000	--	0.25

**NOTE:** When applying the GAPAA Infinity™ Air Purifier, attention must be given to the duct and system design because all these components affect system static pressure. The GAPAA Infinity™ Air Purifier has a higher static pressure than the typical factory supplied furnace and/or fan coil filter (as shown above), but is designed to ensure proper system efficiency and reliability when applied to a properly designed duct system and properly sized HVAC equipment.

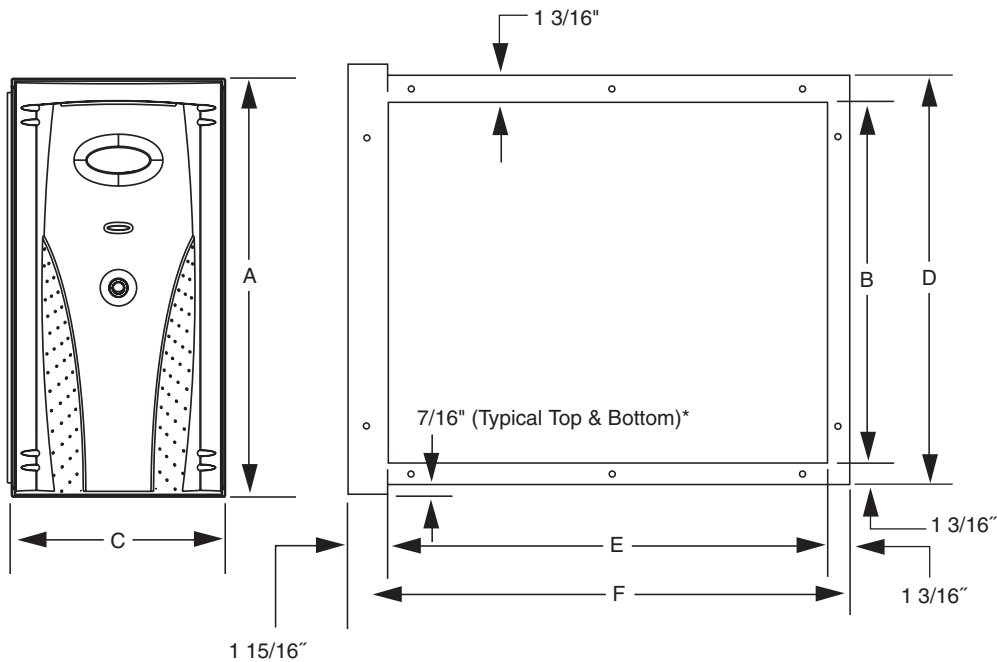

Fig. 2 – Dimensions

A05270